

# Hammerfest 70-G/1

Wandaußenmaß: 530 x 530 cm

Bohlenstärke: 70 mm



Durch Kunden farblich endbehandelt

Kontrolliert durch:

Achtung: Alle angegebenen Maße sind ca.-Maße!

# 3D-Darstellung und Grundriss Hammerfest 70-G/1

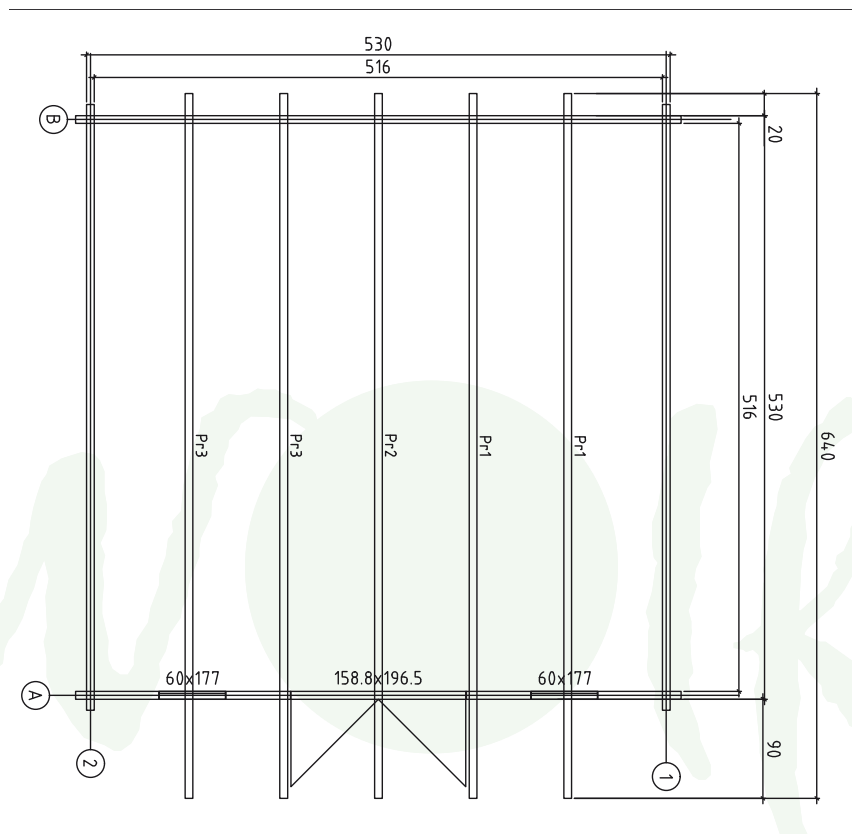
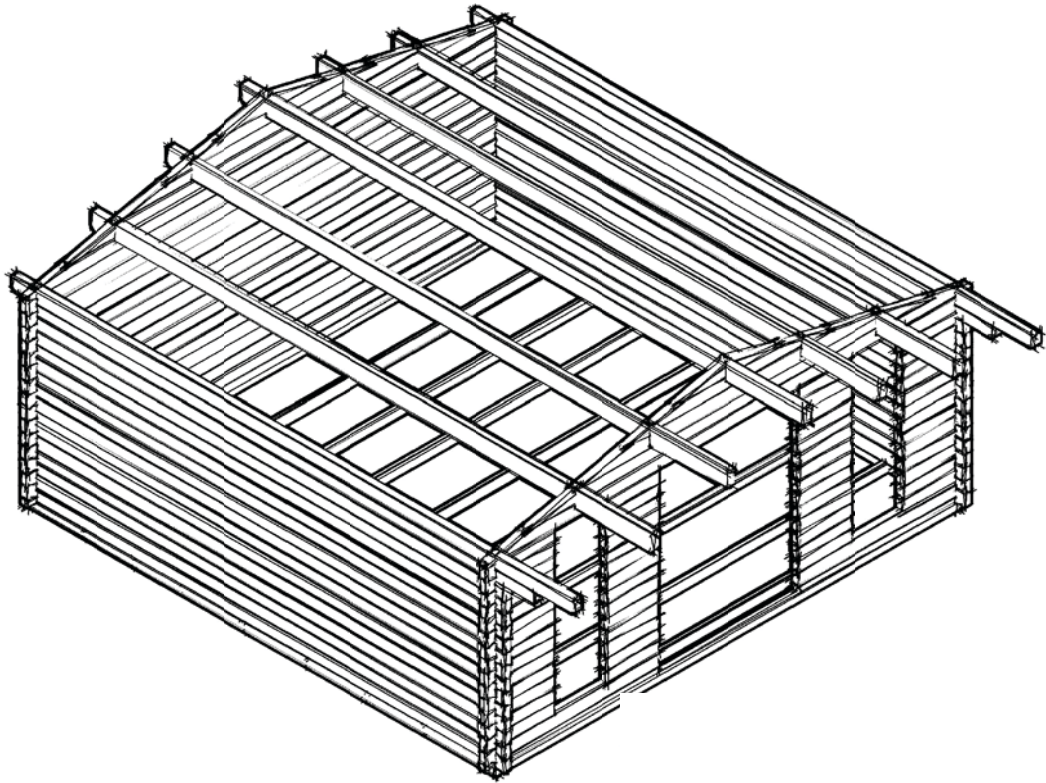

# Lagerholzplan und Fundamentplan Hammerfest 70-G/1

Wir empfehlen als Fundament für Ihr Gartenhaus eine vollflächig,  
festgegründete gepflasterte oder betonierte Fläche.  
Wahlweise ist auch ein Punkt- oder Streifenfundament möglich.

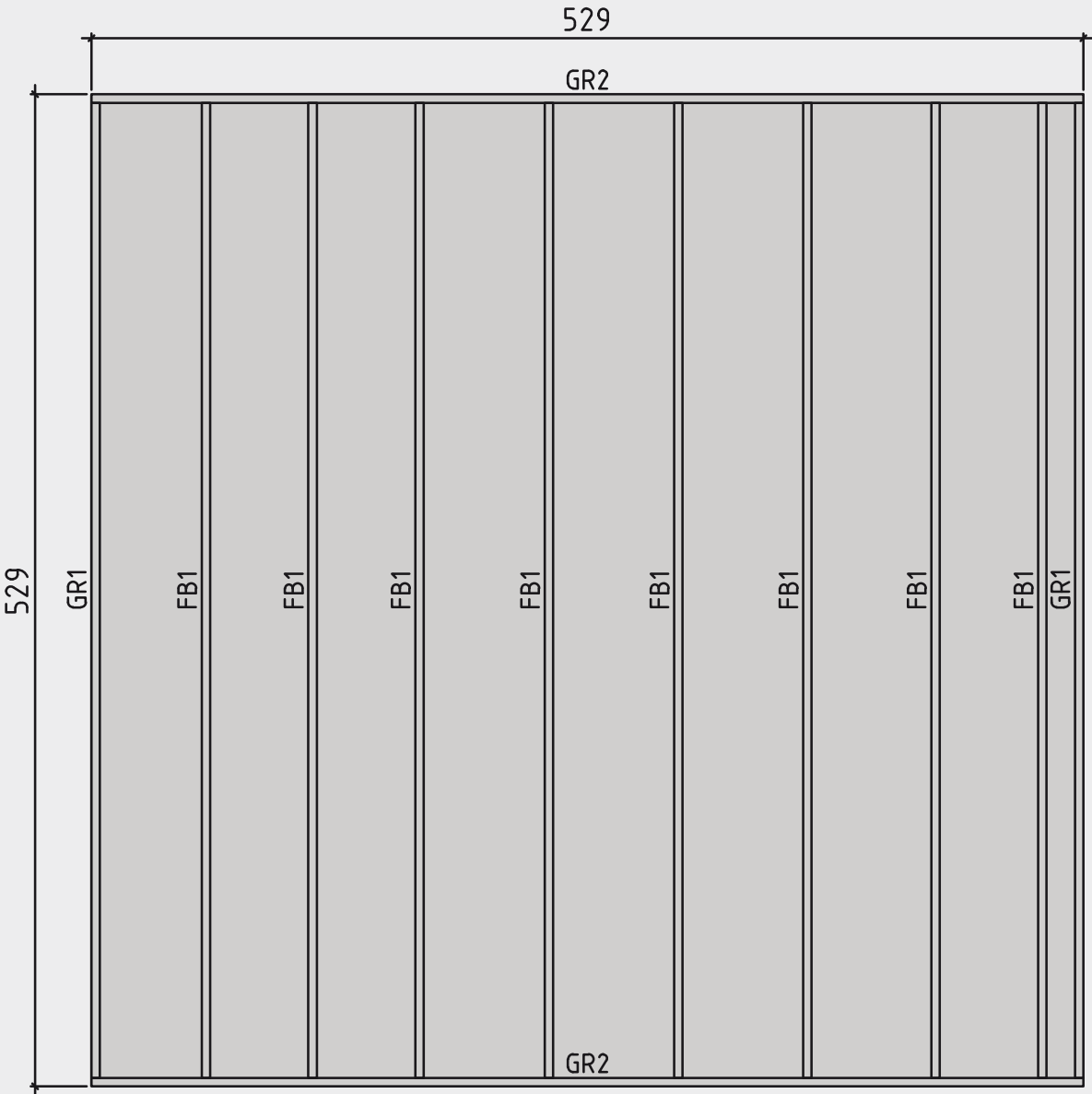









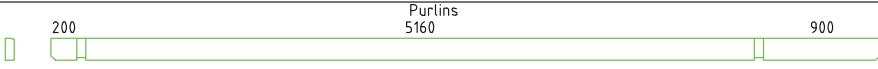
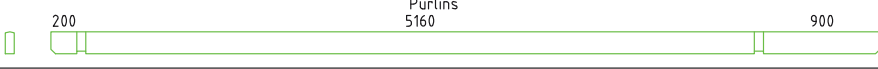
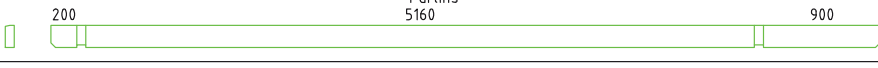

# Teileliste 1

## Hammerfest 70-G/1

Pos		Arv	Profile (mm)	LENGHT (mm)
001		1	70x130	5500
002		1	70x130	5500
003		12	70x130	5500
004		1	70x130	5850
005		1	70x130	6400
006		1	70x130	5500
007		1	70x130	5500
008		12	70x130	5500
009		1	70x130	5850
010		1	70x130	6400
011		2	70x65	1951
012		2	70x130	1951
013		28	70x130	756
014		28	70x130	586
015		2	70x130	5500
016		8	70x123	543
017		2	70x130	3380
018		2	70x130	3440
019		4	70x58	257
020		2	70x130	1719
021		1	70x65	5500
022		15	70x130	5500
GR2	GROUNDFRAME			
		2	45x90	5290
GR1	GROUNDFRAME			
		2	45x90	5200
FB1	FLOORBEAMS			
		8	45x90	5200

# Teileliste 2

## Hammerfest 70-G/1

Pos		Arv	Profile (mm)	LENGHT (mm)
Pr1	 Purlins 5160	2	70x170	6400
Pr2	 Purlins 5160	1	70x170	6400
Pr3	 Purlins 5160	2	70x170	6400
	WINDOW 600x1770	2		
	DOOR 1588x1965	1		
1	Screws/Schrauben/Vis 5x100 mm- For fixing first row of wall logs /Fixierung des ersten Bohlenkranzes/Pour fixer les lames de plancher 	6		
2	Nails/Nägel/Clous 2.1x50 - For fixing floorboards/ Befestigung Fussbodenbretter/Pour fixer les lames de plancher 	495		
3	Nails/Nägel/Clous 2.1x50 - For fixing roofboards/ Befestigung Dachbretter/Pour fixer les voliges 	550		
4	Nails/Nägel/Clous 2.1x50 - For fixing floor edge trims/ Befestigung Fussleisten/Pour fixer les plinthes du plancher 	30		
5	Nails/Nägel/Clous 2.1x50 - For fixing roofing felt fillet/ Befestigung giebelabschlussbrett/Pour fixer la latte de finition de la couverture 	20		
6	Screws/Schrauben/Vis 3,5x50 mm- For fixing roof side boards and roof edge reinforcement Befestigung Traufenbretter und Traufenleisten Pour fixer les planches de rive et le tasseau de refront 	44		
7	Screws/Schrauben/Vis 3,5x50 mm- For fixing fascia boards and diamonds/ Befestigung Giebelblende und Raute Pour fixer les planches de rive et le diamant 	28		
8	Screws/Schrauben/Vis 3,5x50 mm- For fixing fwindow and door trims/ Befestigung Fenster und Türen/ Pour fixer les croisillons des fenetres et des portes 	68		
9	Metal storm Brace/Gewindestange/Tige filetee 10 mm 	4		
10	Shim,Nuts/Mutter ,U-Scheibe/Ecrou,Rondelle 10 mm For fixing storm braces/ Pour fixer les anti tempete/ Für Sturmleisten Pour fixer les croisillons des fenetres et des portes Metal storm Brace/Gewindestange/Tige filetee 10 mm Screws 180 <b>10</b> pcs. KL1 M10 <b>2,18 m 4</b> Plastic caps 5 pcs. 	4/4		

# Teileliste 3

## Hammerfest 70-G/1

Specification for Hammerfest 70 - G 70x130 mm					
POS	ST.	B	H	L	ERKLÄRUNG
FB1	Vt. spetsi				FLOORBEAMS
F2	26,62m <sup>2</sup>	28		5155	FUSSBODENBRETTER 55/42/35
R1	5	70	170	6400	ROOFBEAMS
R2	39,29m <sup>2</sup>	20		3070	Dachbretter 138/108/88
R3	4	20	120	3200	<small>Vaete kattuse kalcenurke</small> Frontboard
R4	4	45	65	3200	<small>Vaete kattuse kalcenurke</small> Frontboard fixing board
R5	4	20	120	3200	<small>Vaete kattuse kalcenurke</small> Girders facade
R6	4	20	90	3200	Topboard
WN06	2	600	1770		<div style="display: flex; align-items: center; justify-content: space-around;"> <div style="text-align: center;"> <p>P3</p> </div> <div style="text-align: center;"> <p>SL- 30x30x1650 mm - 4 pcs.</p> </div> </div>
DR15	1	1588	1965		<div style="display: flex; align-items: center; justify-content: center;"> <div style="text-align: center;"> <p>P2</p> </div> <div style="margin: 0 20px;"> <p>External door</p> </div> </div>
P1	22 m	20	40		Floor edge trim
P2	4	20	90	1945	Fixing boards for door
P3	4	20	90	900	Fixing boards for WN06
P4	2	20	90	1890	Fixing boards for door DR 15
P5	8	20	90	1880	Fixing boards for WN06
P6	2+2	20	90	570 540	Fixing boards for WN06



# Wandplan 1 und 2 Hammerfest 70-G/1

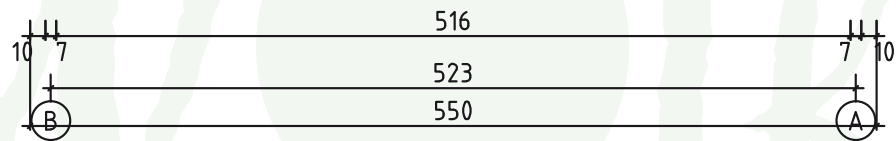
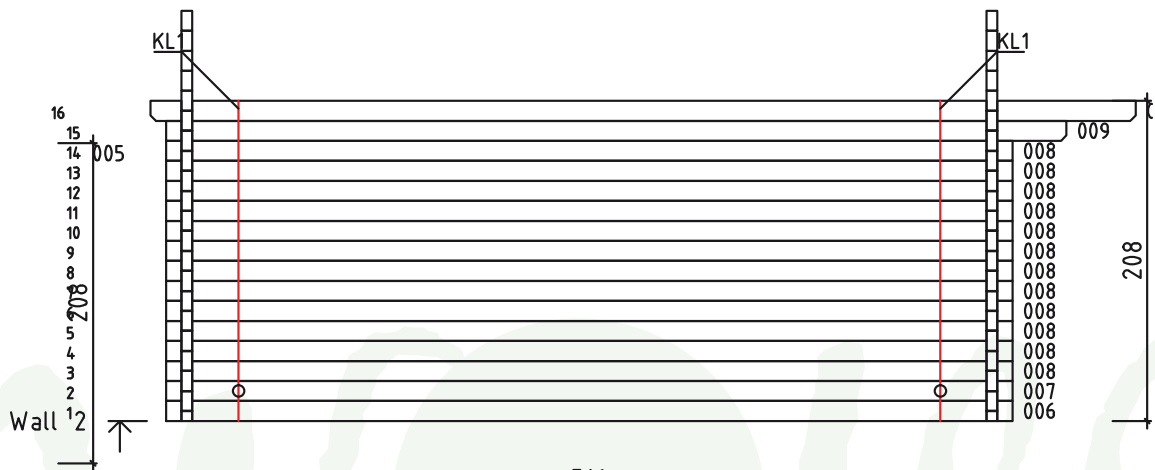
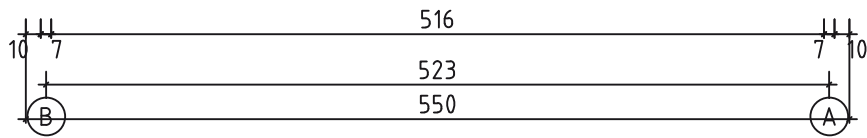
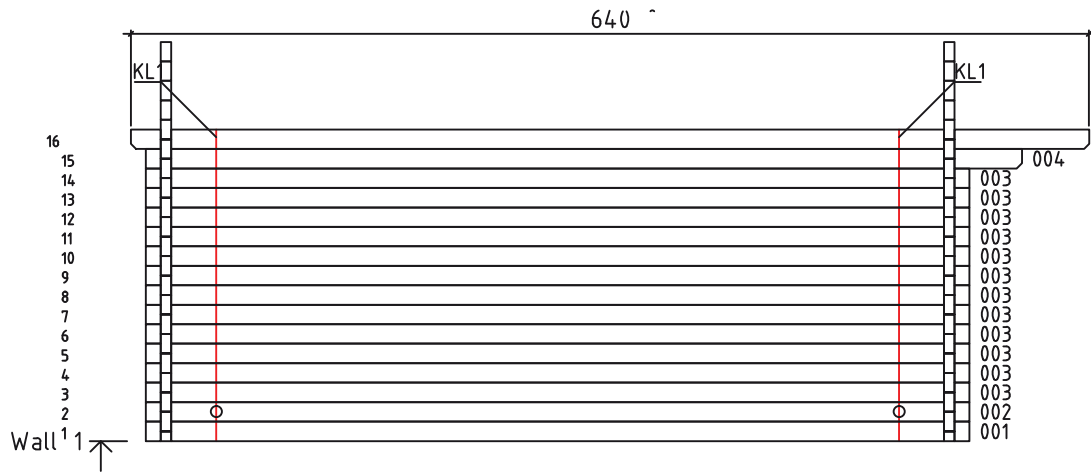

# Wandplan A Hammerfest 70-G/1

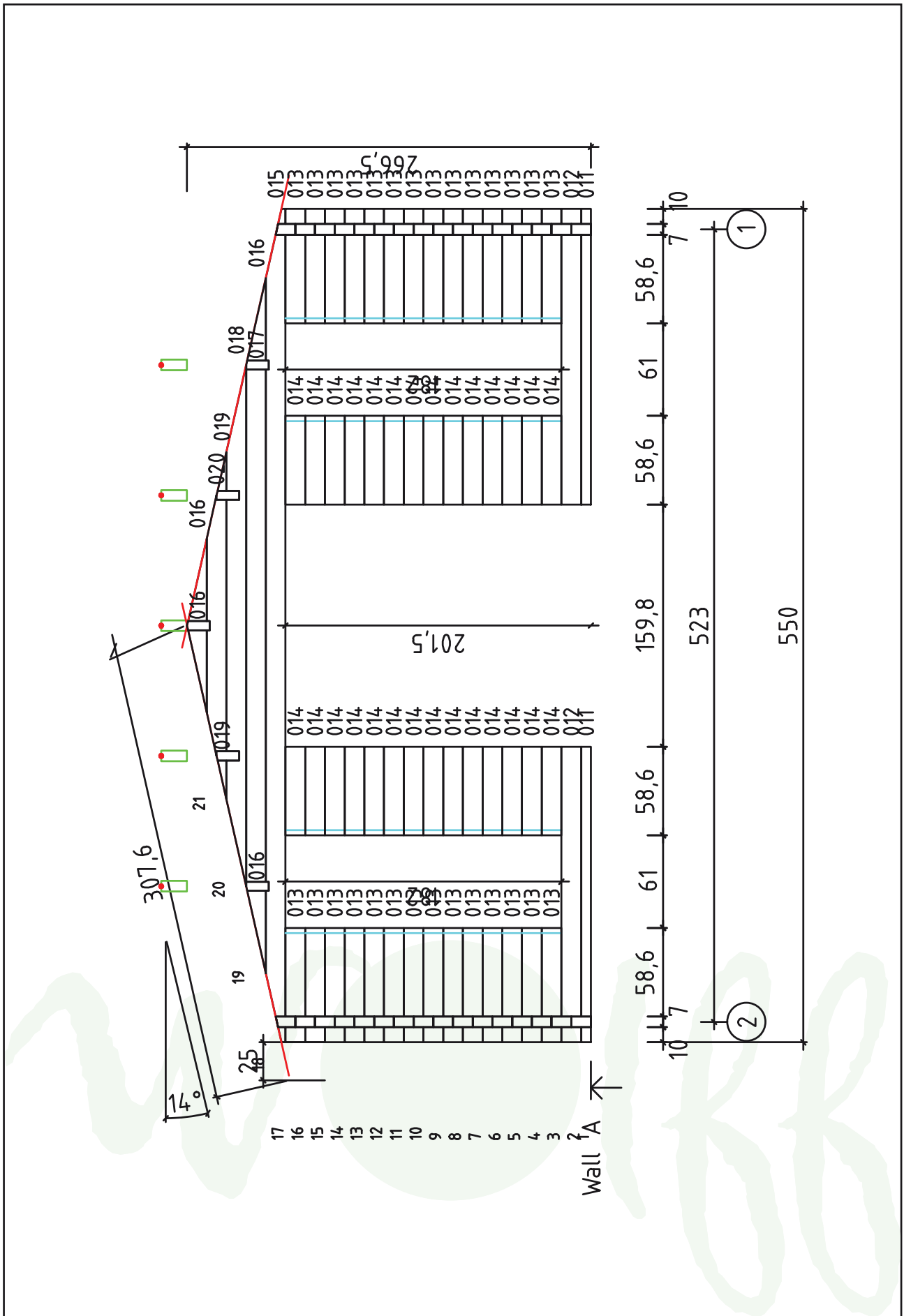



# Wandplan B Hammerfest 70-G/1

