

# Emma 28-A

Wandaußenmaß: 200 x 200 cm

Bohlenstärke: 28 mm



Kontrolliert durch:

Achtung: Alle angegebenen Maße sind ca.-Maße!

# 3D-Darstellung und Grundriss Emma 28-A

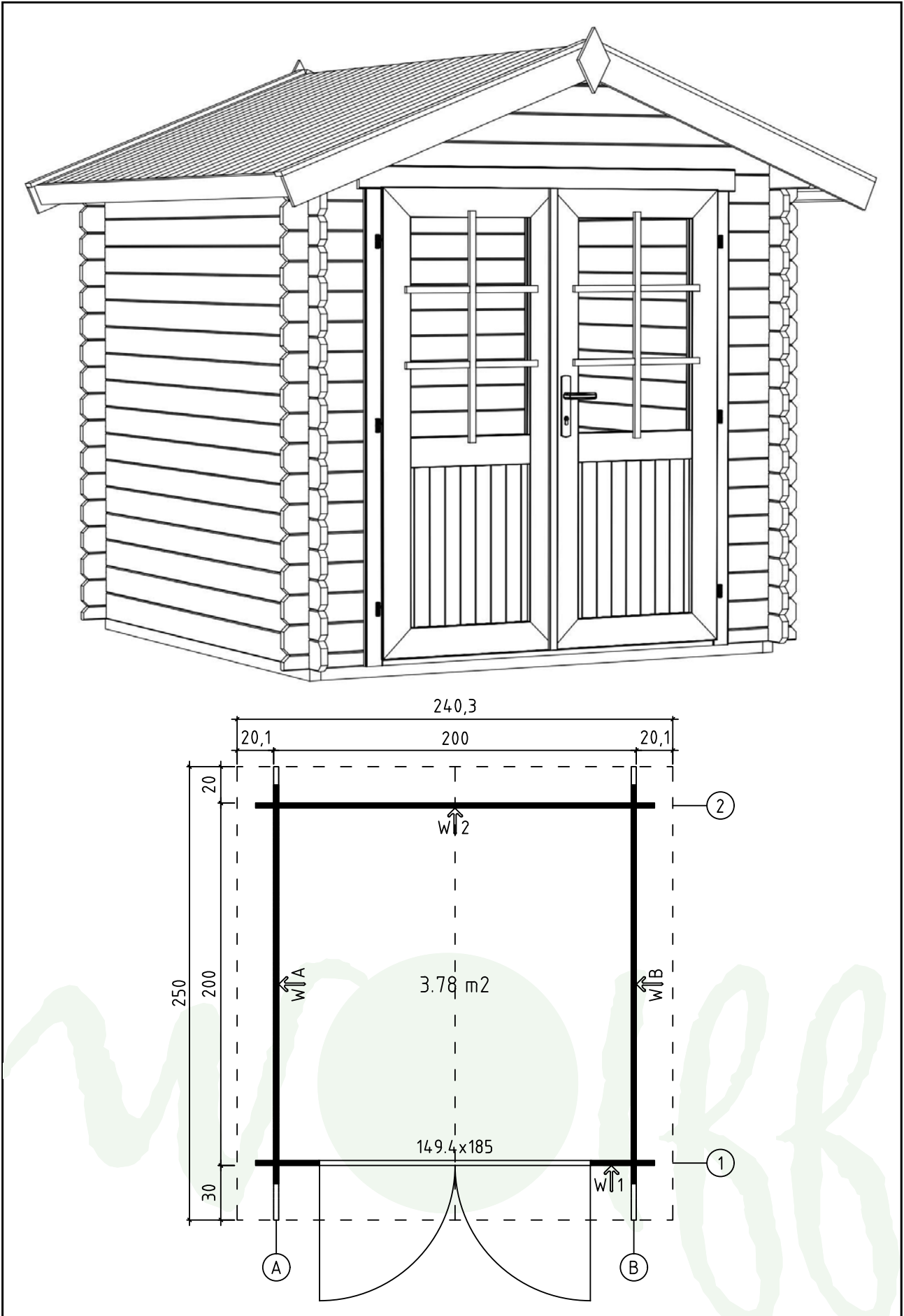





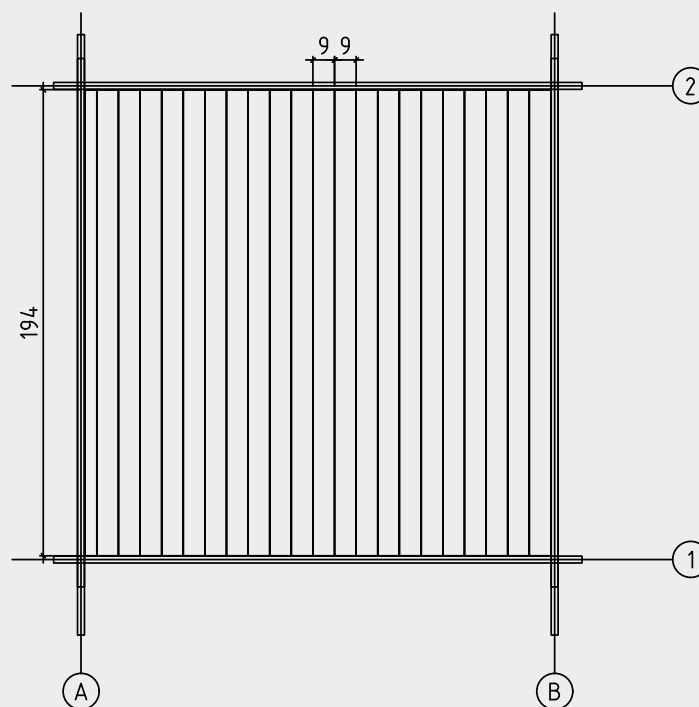
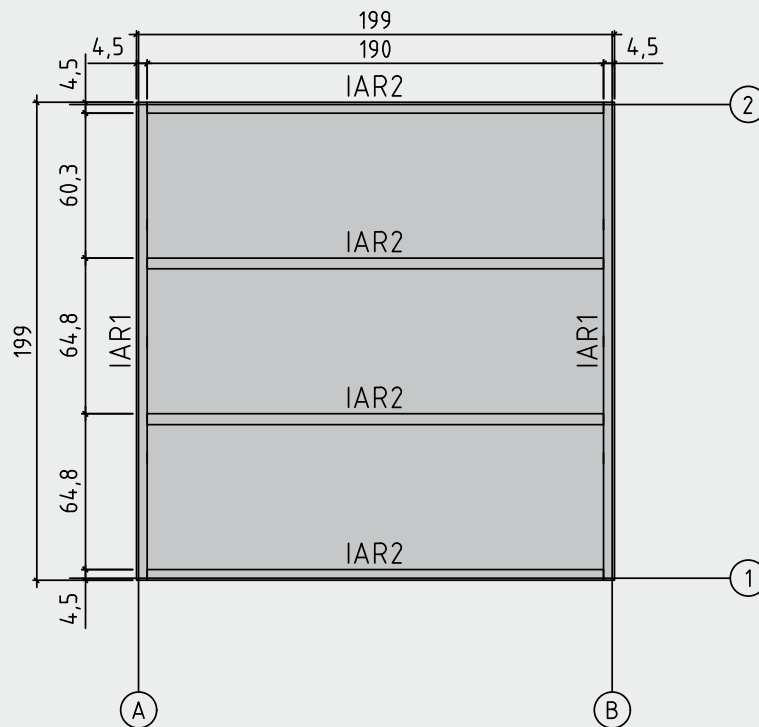







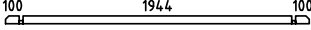
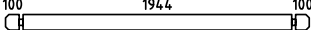
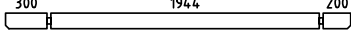
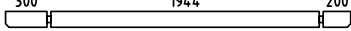
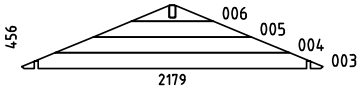
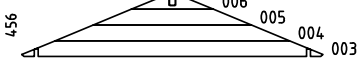
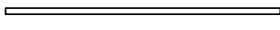

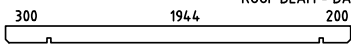

# Fundamentplan und Fußbodenbretter Emma 28-A

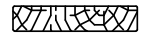
Wir empfehlen als Fundament für Ihr Gartenhaus eine vollflächig, festgegründete, gepflasterte oder betonierte Fläche. Wahlweise ist auch ein Punkt- oder Streifenfundament möglich.













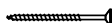





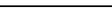
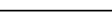

# Teileliste 1

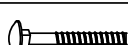
## Emma 28-A

Pos		Q	P (mm)	L (mm)
001		2	28x57	348
002		32	28x114	348
007		1	28x57	2200
008		48	28x114	2200
009		1	28x120	2500
010		1	28x120	2500
W1-1		1		
W2-1		1		
IAR1	FOUNDATION - FUNDAMENT - FONDATION 	2	45x45	1990
IAR2	FOUNDATION - FUNDAMENT - FONDATION 	4	45x45	1900
A-PR1	ROOF BEAM - DACHBALKEN - PANNE DE TOIT 	1	44x120	2500
	FLOOR BOARDS - FUSSBODENBRETTER - LAME DE PLANCHER 	22	90x18	1940
	ROOF BOARDS - DACHBRETTER - VOLIGES 	56	90x18	1300
	FLOOR FILLET - FUSSBODENLEISTE - CORNIERE DE FINITION DU PLANCHER 		18x18	7.76
	ROOFING FELT FILLET - DACHPAPPENLEISTE - BAGUETTE DE FIXATION DU FEUTRE BITUMEUX 	4	18x58	1350
TB-1	FASCIA BOARD - TRAUFBRETT - BANDEAU DE TOIT 	2	18x90	2500
DRV-1	ROOF EDGE REINFORCEMENT - DACHRANDVERSTÄRKUNG - CORNIERE DE RENFORT DE BORD DE TOIT 	2	28x34	2500
KFS-1	STORM PROTECTION - STURMLEISTE - LATTE ANTI-TEMPETE 	4	22x45	2050
	GABLE MOULDING - GIEBELLEISTE - PLANCHE DE RIVE 	4	18x120	1350
HS1	SCREW FOR GEORGIAN BARS - SCHRAUBE FÜR SPROSSEN - VIS POUR CROISILLONS 	12	2.5x20	
HS8	SCREW FOR GABLE SEGMENT - SCHRAUBEN FÜR DECKBLATT - VIS POUR FIXATION LOSANGE DE FINITION 	4	3.5x35	
HS9	SCREW FOR GABLE MOULDING - SCHRAUBEN FÜR GIEBELLEISTE - VIS POUR FIXATION PLANCHE DE RIVE 	16	3.5x50	
HS4	SCREW FOR DOOR FILLET - SCHRAUBE ZUR BEFESTIGUNG TÜRLEISTE - VIS POUR FIXATION BAGUETTE D'ARRET DE PORTE 	5	3x30	

# Teileliste 2

## Emma 28-A

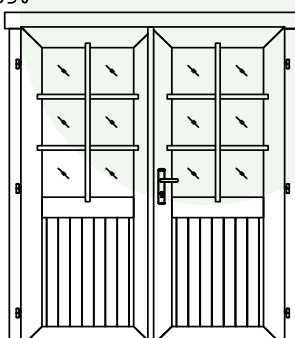
Pos		Q	P (mm)	L (mm)
HS12	SCREW FOR FASCIA BOARDS - SCHRAUBEN FÜR TRAUFBRETTER - VIS POUR FIXATION BANDEAU DE TOIT 	12	4x40	
HS12	SCREW FOR ROOF EDGE REINFORCEMENT - SCHRAUBEN FÜR DACHRANDVERSTÄRKUNG - VIS POUR FIXATION CORNIERE RENFORT DE BORD DE TOIT 	12	4x40	
HS18	SCREW FOR ROOF BEAMS - SCHRAUBEN FÜR DACHBALKEN - VIS POUR FIXATION PANNES DE TOIT 	2	5x120	
HS18	SCREW FOR GABLE - SCHRAUBEN FÜR GIEBEL - VIS POUR FIXATION DES PIGNONS 	4	5x120	
HS16	SCREW FOR 1. WALL BEAM - SCHRAUBE FÜR 1. BOHLENREIHE - VIS DE FIXATIONS 1ere RANGÉE DE MADRIERS AVEC POUTRELLES DE FONDATIONS 	4	5x90	
HS16	SCREW FOR FOUNDATION - SCHRAUBEN ZUR BEFESTIGUNG FUNDAMENT - VIS DE FIXATIONS DES POUTRELLES DE FONDATIONS 	8	5x90	
HS16	SCREW FOR DOOR JAMB - SCHRAUBE FÜR TÜRRAHMEN - VIS DE FIXATION PARTIE HAUTE AVEC MONTANTS DU CADRE DE PORTE 	4	5x90	
HS25	SCREW FOR DOORSTEP - SCHRAUBEN FÜR SWELLE - VIS POUR FIXATION BARRE DE SEUIL 	3	4.5x65	
NF2	ZN NAIL FOR FLOOR FILLET - ZN NÄGEL FÜR FUSSBODENLEISTE - POINTE POUR CORNIERE DE FINITION DU PLANCHER 	20	1.4x40	
SFS	NUT FOR STORM PROTECTION - SCHRAUBENMUTTER FÜR STURMLEISTE - ECROU POUR LATTE ANTI-TEMPETE 	8	D6	
NF4	ZN NAIL FOR ROOF - ZN NÄGEL FÜR DACHBRETTER - POINTE POUR FIXATION VOLIGES DE TOIT 	120	2x50	
NF4	ZN NAIL FOR FLOOR - ZN NÄGEL FÜR FUSSBODENBRETTER - CLOUS POUR PLANCHER 	92	2x50	
BFS	BOLT FOR STORM PROTECTION - BOLZEN FÜR STURMLEISTE - BOULON POUR LATTE ANTI-TEMPETE 	8	6x60	
GS	GABLE SEGMENT - DECKBLATT - LOSANGE DE FINITION 	2		
DFS	WASHER FOR STORM PROTECTION - DICHTSCHEIBE FÜR STURMLEISTE - RONDELLE POUR LATTE ANTI-TEMPETE 	8	D6	
TL4	DOOR HANDLE FITTINGS - TÜRGRIF - POIGNEE DE PORTE 	1		
TL5	SET OF DOOR LOCK COVERS - SCHLOSSBLENDEN - SET DE GARNITURES DE PORTE 	1		
	CYLINDER LOCK - ZYLINDERSCHLOSS - BARILLET DE PORTE 	1	30x35	
	MALE BOLT HINGE FOR DOOR - TÜRBAND - PARTIE MALE DE PAUMELLE DE PORTE 	6		
	STRIKER FOR BARREL BOLT - HÜLSE FÜR GRENDELRIEGEL - GACHE AU SOL DU TARGETTE 	2		
	DOOR - TÜR - PORTE 1494x1850 TUK.2.056.SVP.MMc SGC 	1		

# Wandplan 1 und 2 Emma 28-A

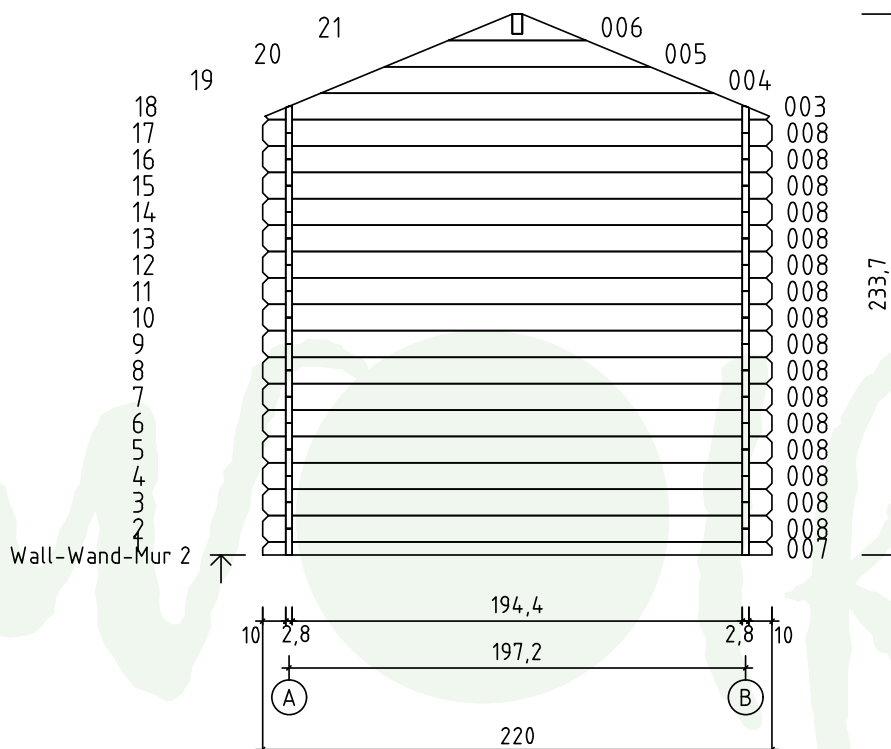
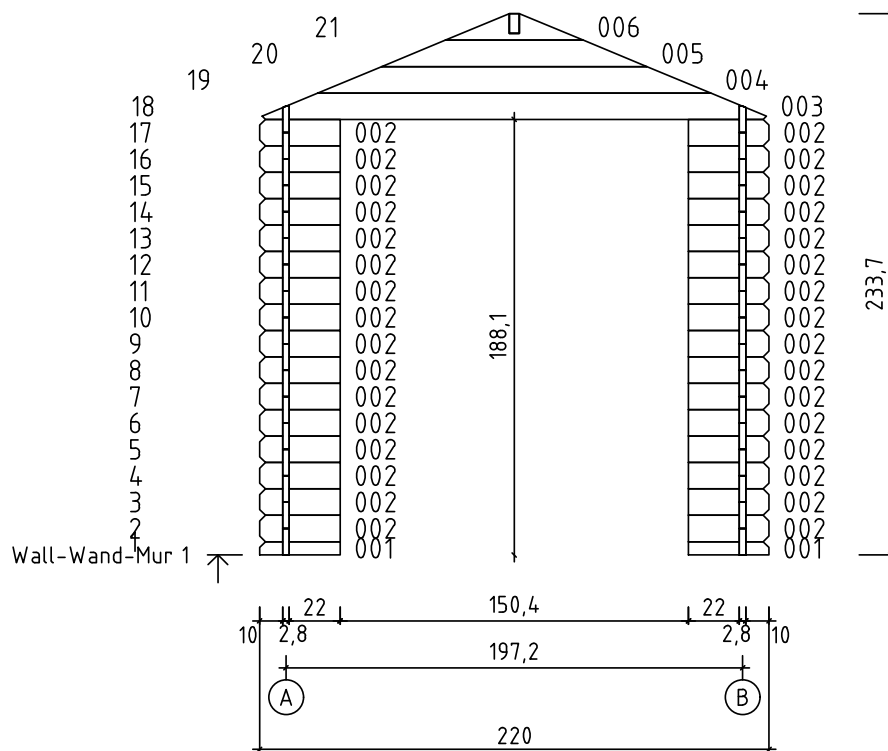

# Wandplan A und B Emma 28-A

